



AL JAZEERAH MARINE

info@aljazeeraahmarine.com
sales@aljazeeraahmarine.com

ADDRESS: EMIRATES INDUSTRIAL CITY SAJAA SHARJAH UAE

+971-54-7070379

www.aljazeeraahmarine.com

D End Or Anchor Shackle

1. End Shackle Introduction

End shackle was also known as Anchor End Shackle, Which has an oval pin and is generally used to connect the crown shackle of the anchor to the swivel forerunner of the anchor chain. Available in Dia 14mm up till 130mm, grade U2 and or/ U3.

2. Specifications

Materials: CM490/CM690

Grade: U2/U3

Key Features:

Made from heavy duty forged steel

Used to join Anchor With Swivel Forerunner

Used in the marine industry to join together mooring and anchor chains

Variety of sizes and weight available

Supplied as an ex-stock item



2. Specifications of D End Shackle

Materials:
CM490/CM690

Grade: U2/U3

Key Features:

Made from heavy duty forged steel
Used to join two anchor chains together
Used in the marine industry to join together mooring and anchor chains
Variety of sizes and weight available
Supplied as an ex-stock item

AL JAZEERAH MARINE

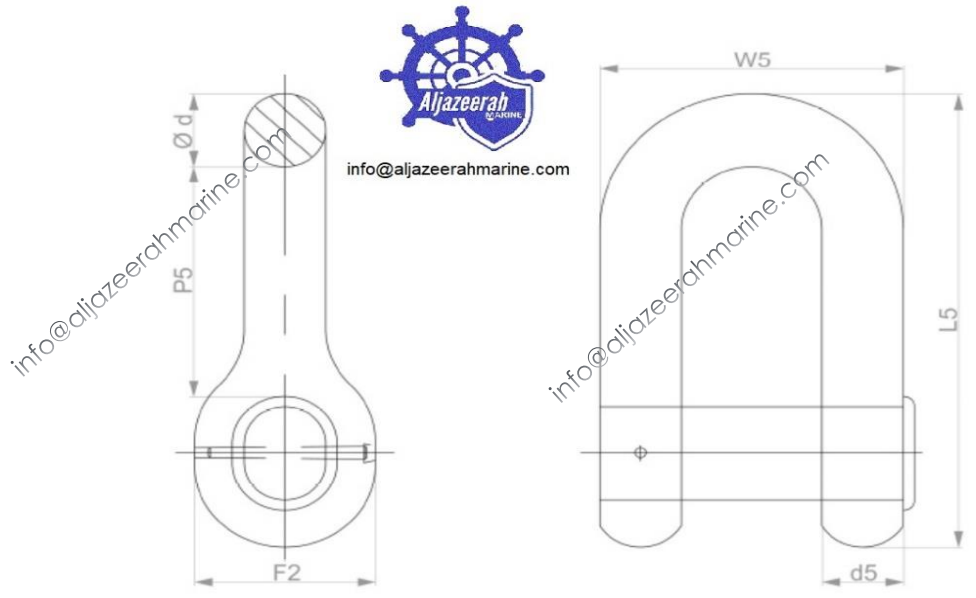

SIZE (d)	d5	L5	P5	W5	F2
12.5	17.5	109	57.5	65	39
14	19.5	122	64.5	73	43
16	22.5	139	73.5	83	50
17.5	24.5	152	81	91	54
19	26.5	165	87	99	59
20.5	28.5	178	94	107	64
22	31	191	101	114	68
24	34	209	110	125	72
26	37	226	120	135	81
28	39	244	129	146	87
30	42	261	138	156	93
32	45	278	147	166	99
34	48	296	156	176	105
36	50	313	166	187	112
38	53	331	175	198	118
40	56	348	184	208	124
42	59	365	193	218	130
44	62	383	202	229	136
46	64	400	212	239	143
48	67	418	221	250	149
50	70	435	230	260	155
52	73	452	239	270	161
54	76	470	248	281	167
56	78	487	258	291	174
58	81	505	267	302	180
60	84	522	276	312	186
62	87	539	285	322	192
64	90	557	294	333	198
66	92	574	304	343	208
68	95	592	313	354	211

SIZE (d)	d5	L5	P5	W5	F2
70	98	609	322	364	217
73	102	635	336	380	226
76	106	661	350	395	236
78	109	678	359	406	242
81	113	705	373	421	251
84	118	731	386	437	260
87	122	757	400	452	270
90	126	783	414	468	279
92	129	800	422	478	285
95	133	827	437	494	295
97	136	844	446	504	301
100	140	870	460	520	310
102	143	887	468	530	316
105	147	914	483	546	326
107	150	931	492	556	332
111	155	966	511	577	344
114	160	992	524	593	353
117	164	1018	538	608	363
120	168	1044	552	624	372
122	171	1061	560	634	378
124	174	1079	570	645	384
127	178	1105	584	660	394
130	182	1131	598	676	403
132	185	1148	606	686	409
137	192	1192	630	712	425
142	199	1235	652	738	440
147	206	1279	676	764	456
152	213	1322	699	790	471
157	220	1366	722	816	487
162	227	1409	745	842	502



AL JAZEERAH MARINE EQUIPMENT TRADING
ADDRESS: EMIRATES INDUSTRIAL CITY SHARJAH UAE.
EMAIL: info@aljazeeraahmarine.com
WEB: www.aljazeeraahmarine.com

www.aljazeeraahmarine.com

www.aljazeeraahmarine.com